



Clear Vue Cyclones

CV1800 and CVMAX Installation Guide



Clear Vue
Cyclones

145 Nix Road
Liberty, SC 29657
888-299-0221

www.clearvuecyclones.com

Disclaimers & Warnings

WARNING: All persons, by purchasing a motorized dust collection system, motor, or individual parts from CLEAR VUE CYCLONES, or using these instructions which are provided as suggestions only, agree to the following disclaimer:

Installing and/or operating this motorized dust collection system, or use of individual parts, involves the risk of serious bodily injury or even death. The buyer and user accept total responsibility for any and all operation or use that may lead to personal injury, economic loss, social distress, other losses, costs and damages. Seller is not responsible for injuries and or damages of any kind resulting from operating this motorized dust collection system, motor, or use of individual parts or instructions.

All Rights Reserved, January 2018

Duplication of any part of this manual without expressed written permission from Bushey Enterprises, Inc. is prohibited.

IMPORTANT!

Minimum Recommended Ceiling Height

A minimum floor-to-ceiling height of 8 feet (96 inches) is required. The content of this manual is based upon the assembly of the system under an 8' ceiling.

If your ceiling is lower than this recommended height, please contact us at 888-299-0221 to discuss your alternate installation options.

Leaks

To maximize performance of your dust collection system, it will be imperative to check for leaks. Leaks on the suction side of the system will reduce the CFM (cubic feet per minute) performance levels. We recommend the sealing of all connections in your ducting.

Leaks in the collection drum or at the bottom of the cyclone are a major problem. Such leaks will cause an up-flow of air through the cyclone and prevent the dust from entering the collection drum. This will affect the separation efficiency of the cyclone and more dust will advance through to your filters, which may cause blockage.

Leaks found anywhere after the dust reaches the blower may be blown back into your shop. This is a hazardous situation and these leaks should be sealed immediately.

Testing for leaks can be done by performing a "smoke test". With any smoke-producing device (such as an incense stick), waft the smoke around the various seams of the system. Leaks in the ducting will cause the smoke to disperse. Leaks around the base of the cyclone will cause the smoke to be pulled in. Seal any leaks for optimal performance.

This page is intentionally left blank.

Table of Contents

Disclaimers & Warnings.....	1
Dimensional Drawing	4
Cyclone Components.....	5
Specifications	6
Installation Tools	7
Box Contents.....	8
Installing Clear Vue Wall Mounting Brackets*	9
Building your own Wall Mounting Brackets	10
Constructing the Hanger Plate & Motor Assembly.....	11
Attaching the Impeller	13
Hanging the Motor/Impeller Assembly	13
Assembling the 90° Filter Transition (<i>filtered systems only</i>).....	15
Attaching the 90° Filter Transition (<i>filtered systems only</i>).....	16
Attaching the Straight 8” Exhaust (<i>non-filtered systems only</i>).....	17
Attaching the Blower Housing to the Cyclone Body	18
Installing the Intake and Leveling the Cyclone.....	19
Building your own Filter Clean Out Box (<i>filtered systems only</i>).....	20
Assembling the Flangeless Filter Stack (<i>filtered systems only</i>)	21
Installing the Filter Stack Assembly (<i>filtered systems only</i>).....	22
Modifying the Collection Drum Lid	23
Installing the Collection Drum and Final Adjustments	24
Electrical – Single-Phase Motors	25
Electrical – Three-Phase Motors.....	27

Dimensional Drawing

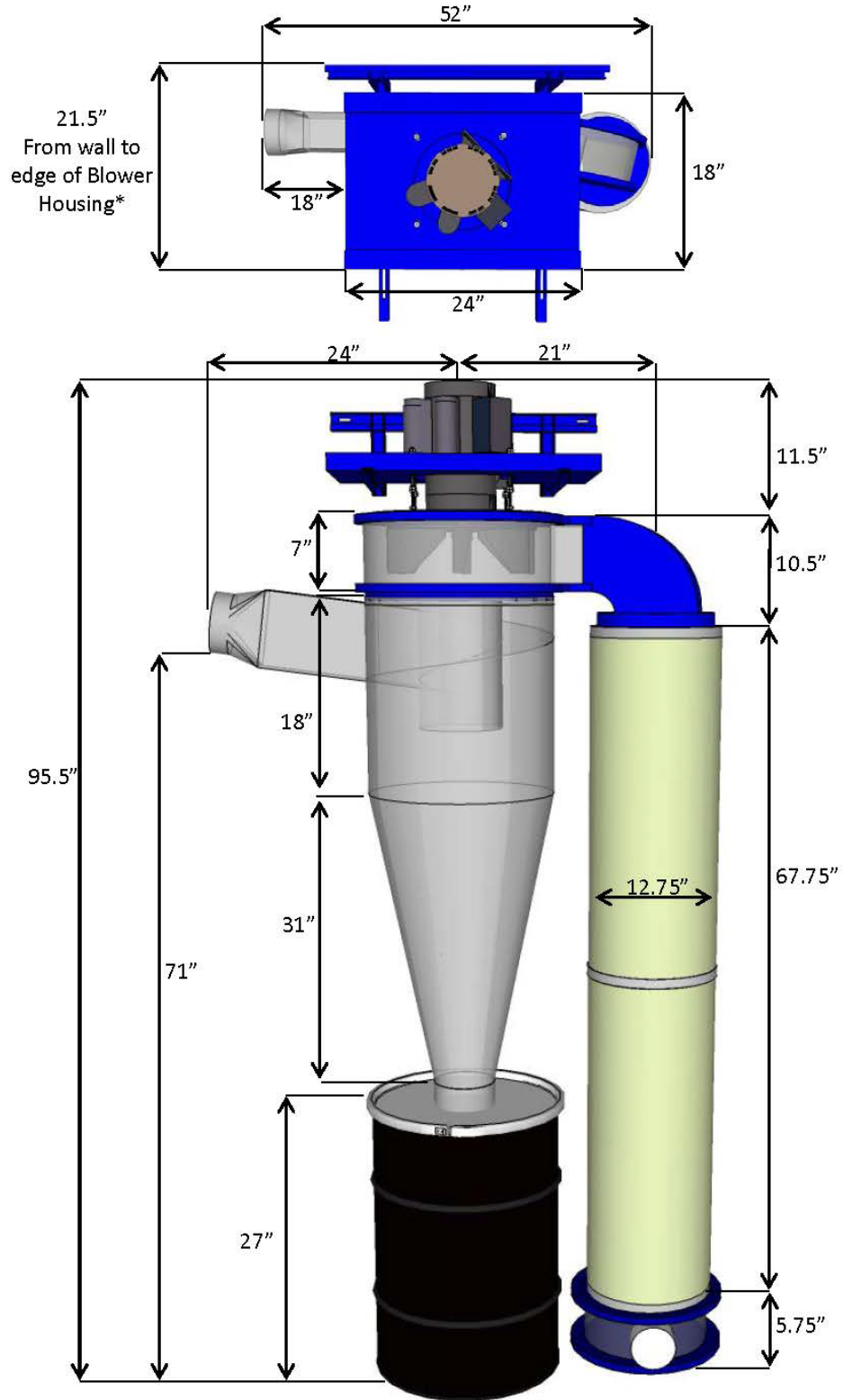

Model shown is CV1800LH/CVMAX with filters. CV1800RH measurements are identical, but transposed.
Collection Bin, Wall Mounting Brackets and Filter Clean Box are sold separately.

*Depth will vary based on size and rotation of the Blower Housing.

Cyclone Components

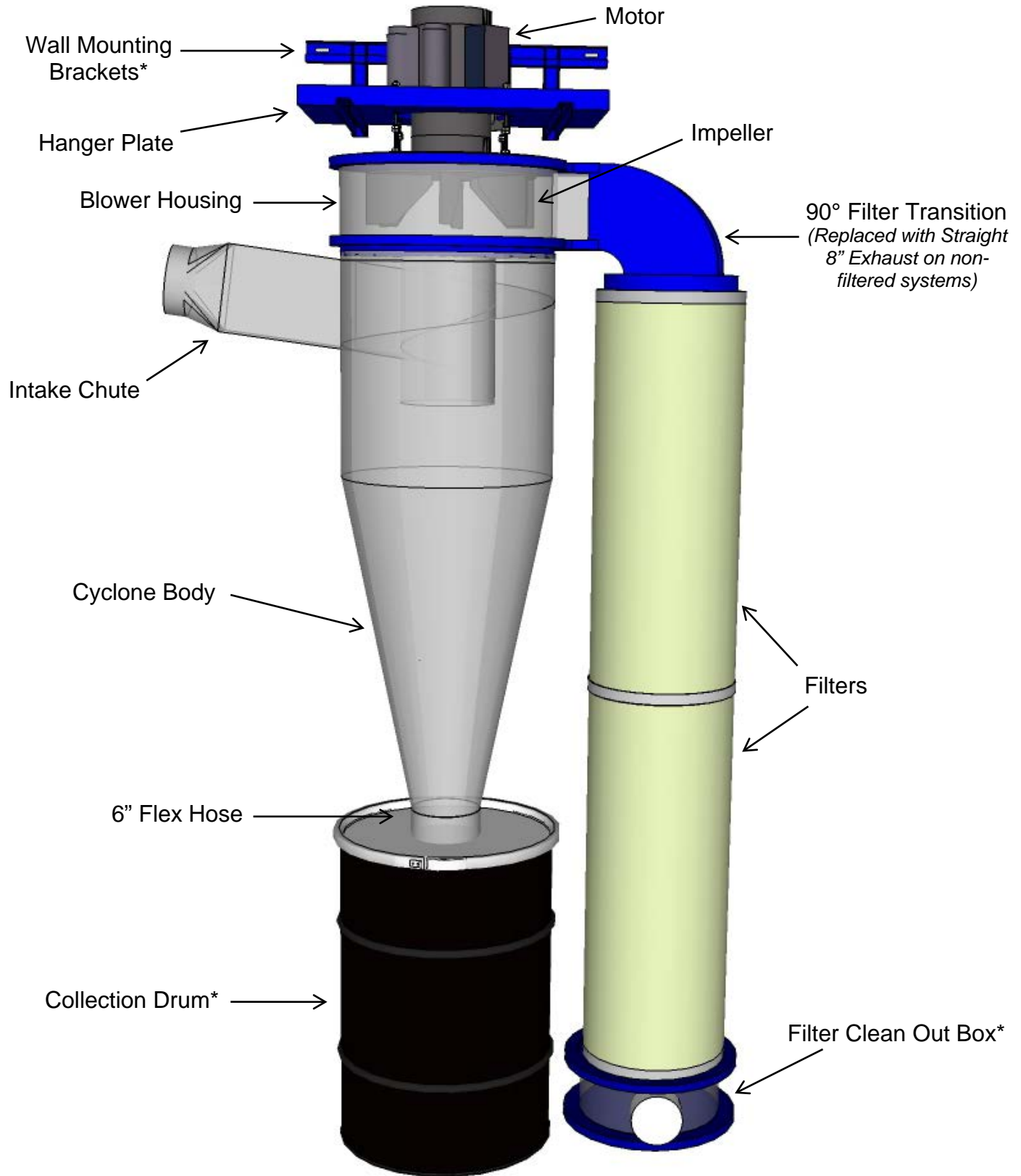

**Collection Drum, Wall Mounting Brackets and Filter Clean Out Box sold separately.*

Specifications

	CV1800	CVMAX
System Performance	1,442 CFM at baseline static pressure of 2.25"	1,935 CFM at baseline static pressure of 2.25"
Footprint with Filters*	52" x 21-½"	52" x 21-½"
Footprint without Filters*	45" x 21-½"	45" x 21-½"
Minimum Height**	96"	96"
Weight with Filters***	Single Phase – 164 lbs Three Phase – 214 lbs	Single Phase – 164 lbs Three Phase – 214 lbs
Weight without Filters***	Single Phase – 130 lbs Three Phase – 180 lbs	Single Phase – 130 lbs Three Phase – 180 lbs
Blower Assembly	15" steel, backward-inclined impeller	16" steel, backward-inclined impeller
Cyclone Diameter	18"	18"
Intake Size	6.25" ID (sized for 6" sewer & drain PVC – ASTM D2729 or SDR 35)	8.5" ID (sized for 8" sewer & drain PVC – ASTM D3034 or SDR 35)
Intake Angle	Upward, 11°	Upward, 11°
Country of Origin	USA	USA
Assembly Time	4-8 hours, with 2 people	4-8 hours, with 2 people
Motor:		
Manufacturer	Leeson Motor Company	Leeson Motor Company
HP Rating	5 HP, non-TEC	5 HP, non-TEC
Speed	3,450 rpm	3,450 rpm
Current	Single Phase – 20.8 FLA at 230V Three Phase – 12.2 FLA at 230V 6.1 FLA at 460V	Single Phase – 20.8 FLA at 230V Three Phase – 12.2 FLA at 230V 6.1 FLA at 460V
Manual Overload Protection	Yes	Yes
Electrical:		
Minimum Circuit Size	Single Phase – 30 amps Three Phase – 15 amps at 230V 10 amps at 460V	Single Phase – 30 amps Three Phase – 15 amps at 230V 10 amps at 460V
Minimum Recommended Wire Size	10 gauge	10 gauge
Filters:		
Manufacturer	Wynn Environmental	Wynn Environmental
Model #	9B300NANO	9B300NANO
Material	100% Nanofiber laminate	100% Nanofiber laminate
Area	300 sq ft each	300 sq ft each
Separation Efficiency	99.999% at 0.5 micron	99.999% at 0.5 micron
MERV Rating	15	15
Dimensions	12.75" OD x 34" H x 8.4" ID	12.75" OD x 34" H x 8.4" ID

* Dimensions based on intake positioned 180° from exhaust. Depth/width will vary depending on rotation.

** Lower ceiling height installations available. Please contact Customer Service at 888-299-0221 for more details.

*** System weight only. Collection drum, Wall Mounting Brackets and Filter Clean Out Box not included.

Installation Tools

Items Needed for Installation:

- $\frac{9}{16}$ " Wrench
- $\frac{7}{16}$ " Wrench
- $\frac{3}{32}$ " Hex Key
- Drill
- Level
- Hammer
- 6' Ladder
- Tape Measure
- Box Cutter
- (1) tube of Caulk
 - *ALEX PLUS Acrylic Latex Caulk plus Silicone (color Crystal Clear) is recommended simply because it dries the clearest. Other brands/types may be used.*
- Collection Drum with Lid
 - Container must be round, airtight, and not subject to collapse.
 - Traditional installation allows 27" of space for the Collection Drum. Taller drums require system to be mounted higher.
 - See the section on *Modifying the Collection Drum Lid* for additional items that may be needed.
- $\frac{1}{2}$ " thick by 1" wide gasket or weather stripping (for tight seal on the lid of the Collection Drum).

Items Needed to build Wall Mounting Brackets*:

- ($\frac{1}{2}$) sheet of $\frac{3}{4}$ " plywood
- (1) 2" x 4" x 8'
- (8) #12 x 3" (or longer) screws
- (20) 1- $\frac{1}{2}$ " screws
- (8) #12 x 2- $\frac{1}{4}$ " screws
- Wood glue

Items Needed to build Filter Clean Out Box*:

- ($\frac{1}{2}$) sheet of $\frac{3}{4}$ " plywood or MDF
- Wood glue
- Nails
- $\frac{1}{2}$ " thick by 1" wide gasket or weather stripping

*Wall Mounting Brackets and Filter Clean Out Box are available for purchase at www.clearvuecyclones.com.

Box Contents

Cyclone Box:

- Cyclone body
- Intake chute
- 6" length of 6" flex hose
- (2) 6" flex hose clamps
- Relay *(not included with purchase of Electrical Box)*
- Filter Clamp and hardware *(filtered systems only)*:
 - (1) ¼"-20 x 1" bolt
 - (1) ¼"-20 flat washer
 - (1) ¼"-20 wing nut
- Straight 8" Exhaust *(non-filtered systems only)*

Materials Box:

- Blower Housing with motor plate
- Impeller
- Hanger Plate
- Wall Mounting Brackets *(if purchased)*
- 90° Transition sides and end plate *(filtered systems only)*
- 90° Filter Transition inner and outer plastic sides *(filtered systems only)*
- Hardware kit:
 - (4) ⅜" x 1-¼" bolts
 - (4) ⅜" flat washers
 - (4) ⅜" lock washer
 - (8) ⅝" x 1" rubber bushings
 - (4) #6-18 x ⅜" pan head screws
 - (6) #6 x 1-⅝" sheet rock screws
 - (7) #6 x 1-¼" sheet rock screws
 - (8) ¼"-20 lock washers
 - (28) ¼"-20 flat washers
 - (24) ¼"-20 nuts
 - (4) ¼"-20 x 7" threaded rods
 - (4) ¼"-20 x 1-½" hex bolts
- Taper-lock bushing with (3) bolts

Motor Box:

- Leeson motor
 - Motor key will be taped to motor – *do not discard!*

Filters (if applicable):

- *Shipped separately from Wynn Environmental for continental US orders*

Filter Clean Out Box (purchased separately):

- Filter Clean Out Box

Electrical Box (purchased separately):

- *Shipped separately for continental US orders*
- Electrical junction box with relay
- 6' whip
- (1) remote



Check the contents of your boxes as soon as possible to verify there was no damage sustained during shipment. If there are any issues, please contact Customer Service at 888-299-0221.

Installing Clear Vue Wall Mounting Brackets*

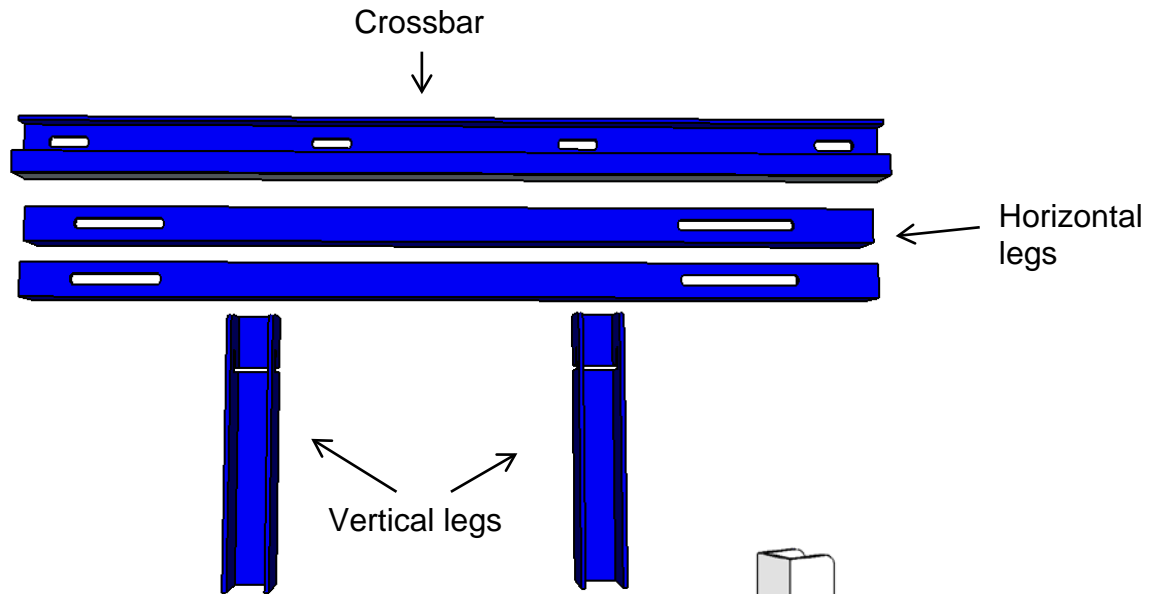

1. Assemble legs:
 - a. Secure (1) horizontal leg and (1) vertical leg of the bracket using bolts and nuts provided. Orientation of bolt-head does not matter.
 - b. Follow same procedure for second bracket.
2. Measure where top of the crossbar will be mounted on the wall and mark accordingly. Our 8' installation requires the top edge of crossbar to be mounted at 95.5".

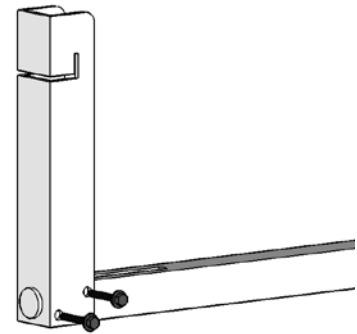

If your ceilings are higher than 8' and you are using a collection drum that is taller than 27", you will need to increase the mounting height of your brackets accordingly. The measurement does not need to be exact – a longer length of flex hose can be used between the base of the cyclone and collection drum to take up any excess height.

3. Slide assembled legs onto crossbar.
 - a. Position legs accordingly – the legs can be spaced so that the hanger plate is situated either lengthwise or widthwise.
4. Mount crossbar to the studs of the wall, using 3" lag bolts (not included).
 - a. *Note: some customers may choose to mount the brackets to a piece of plywood before mounting to the studs. Ensure the plywood extends the entire assembled height of the brackets.*

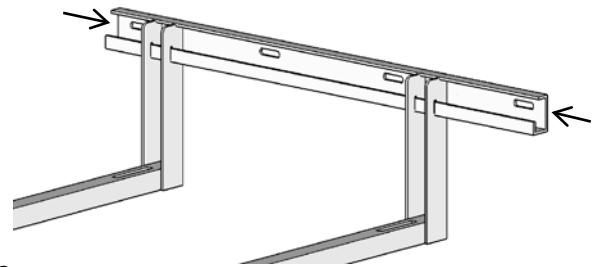

If you choose to mount the crossbar to the wall first before attaching the legs, use the inner holes for mounting as the legs will not slide past the lag bolts. Once legs are attached, you can the fasten lag bolts in the outer set of holes as well.

**For brackets purchased after 02/01/2016. Please contact Customer Service for assembly instructions for brackets purchased prior to this date.*

Building your own Wall Mounting Brackets



These brackets are intended for use with single-phase systems only. If mounting a three-phase system, the brackets must be welded steel to support the motor weight.

Note: Wall Mounting Brackets are available for purchase at www.clearvecyclones.com.

- Cut the bracket components:

	15" Blower (CV1800)	16" Blower (CVMAX)
(2) vertical legs from 2" x 4" x 8'	9" long	9" long
(2) horizontal legs from 2" x 4" x 8'	18" long	20" long
(1) bracket back from 3/4" plywood	12" x 26"	12" x 26"
(2) bracket sides from 3/4" plywood	9" x 19-1/2"	9" x 21-1/2"

- Join the vertical and horizontal legs:
 - Using (2) #12 x 2-1/4" or longer screws, join the vertical (shorter) legs to the horizontal (longer) legs by driving the screws through the vertical leg into the end grain of the horizontal leg.
 - Repeat for second bracket.

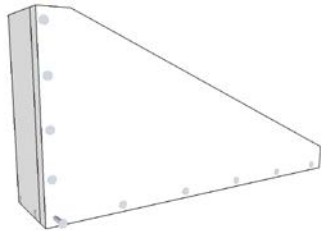
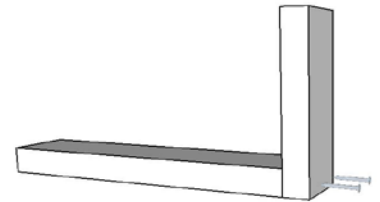

- Attach the sides to the bracket:
 - Glue the bracket sides to the "L" bracket. Reinforce with (10) 1-1/2" screws.
 - If desired, trim side brackets down to triangular shape.
 - Repeat for second bracket.

- Mount brackets to the wall:
 - Mount the top of the bracket back 96" above the floor.

If your ceilings are higher than 8' and you are using a collection drum that is taller than 27", you will need to increase the mounting height of your brackets accordingly. The measurement does not need to be exact – a longer length of flex hose can be used between the base of the cyclone and collection drum to take up any excess height.

- Attach the bracket back to the wall by driving at least (8) or more #12 x 3" screws through the bracket into the wall studs.

These screws will be holding the weight of the entire unit, so #12 x 3" or longer screws are recommended.

- Attach the assembled bracket sides to the mounted bracket back using (4) #12 x 2-1/4" screws. The tops and outside edges of the components should align.

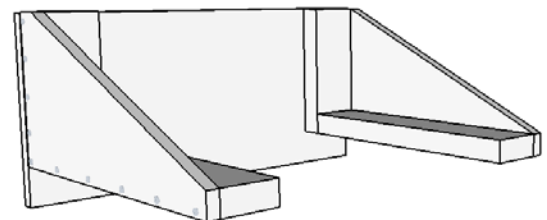

Constructing the Hanger Plate & Motor Assembly

1. Assemble the threaded rod hardware:
 - a. Set up (4) threaded rods with the items shown. Leave about 2 to 2 ½" between item groups.

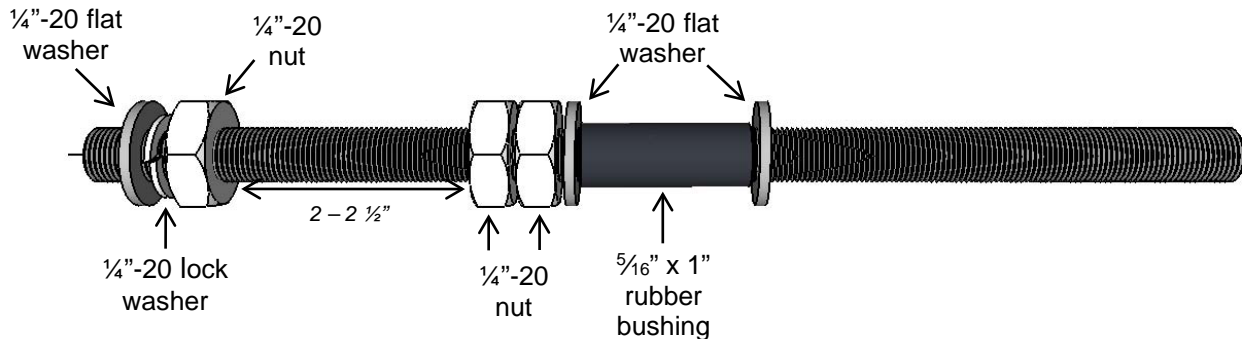

2. Locate the motor plate – it is the round disc secured to the top of the blower housing with (6) clips. Separate it from the blower housing by removing the (6) clips and associated hardware. Set these clips and hardware aside.

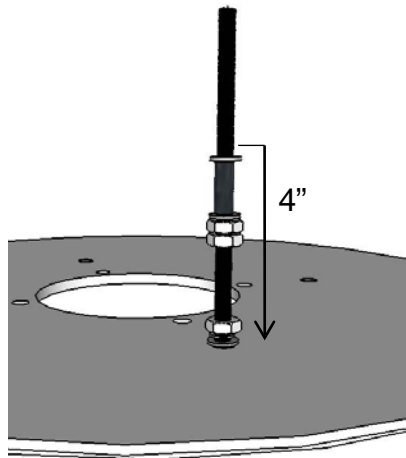

3. Insert (1) threaded rod assembly into each hole of the motor plate, with the hardware situated down.
 - a. Thread rod into T-nuts until they almost “bottom out”.



The T-nuts are installed on the rabbet side, which is facing down in the picture. Make sure the T-nuts are on the bottom side before inserting the threaded rod from the top.

- b. Once installed, the top washer should be approximately 4" above the motor plate.
 - c. Repeat for (3) remaining threaded rod assemblies.

4. Slide the hanger plate onto the threaded rod assemblies.

The strips on the hanger plate should be facing UP.

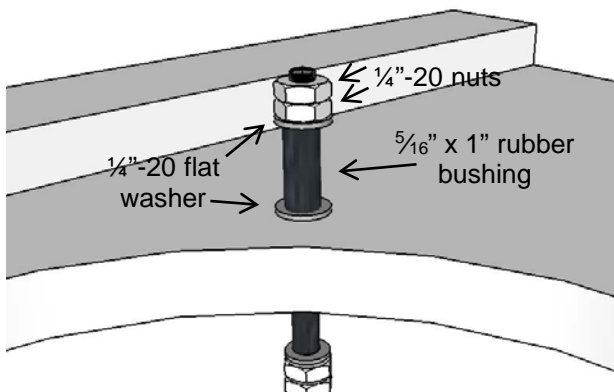

5. Install the remaining hardware above the hanger plate as pictured.
 - a. Leave the ¼"-20 nuts above and below the hanger plate loose as they will be used to level the cyclone after it is hung.

6. Stand the motor on end, with the shaft facing up towards the ceiling.
7. Attach the motor to the hanger plate assembly:
 - a. Turn the hanger plate assembly over so that the hanger plate is down and set it on the motor. Be sure the holes on the motor plate align with those on the face of the motor.
8. Install (1) $\frac{3}{8}$ " x 1- $\frac{1}{4}$ " bolt through each of the holes on the motor plate into the holes on the face of the motor, using (1) $\frac{3}{8}$ " lock washer and (1) $\frac{3}{8}$ " flat washers per bolt.
9. Tighten each motor bolt securely.

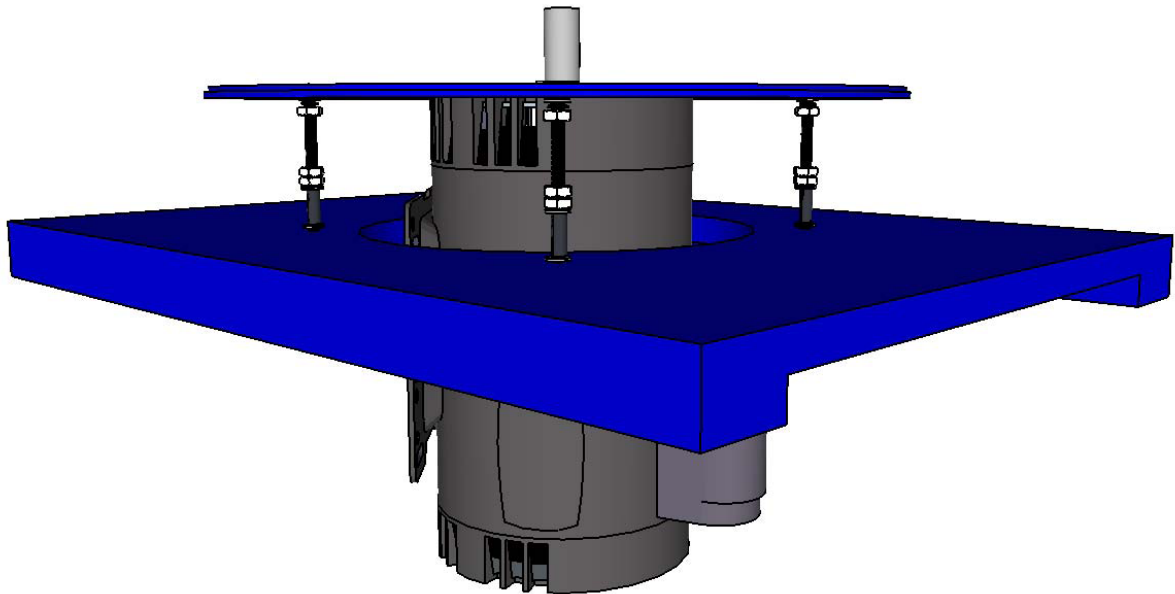
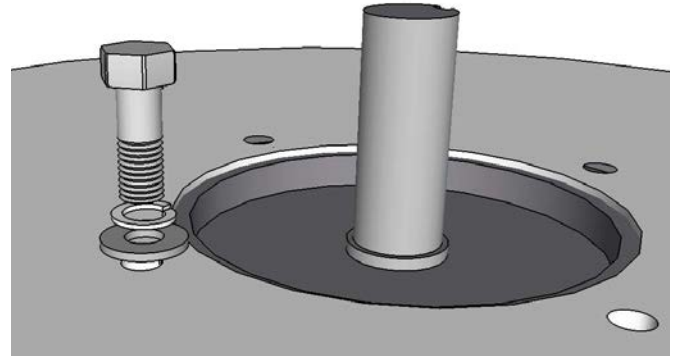

Completed Hanger Plate & Motor Assembly



Do NOT turn the motor on until the system is completely assembled, including the collection drum. Doing so may cause the circuit breaker to trip, physical damage to the system and/or bodily harm.

Attaching the Impeller



Improper installation of your impeller can lead to the impeller coming off during operation. Significant damage to your system and/or bodily harm can result. It is imperative that you read and follow these directions closely. Detailed assembly videos can be found under the Education Center/Assembly Instruction section of our website at www.clearvuecyclones.com.

1. Remove the MDF packing plate affixed to the impeller and discard it.
2. Locate the taper-lock bushing (and screws). It will either be installed on the impeller, or packed in a small box, inside of the materials box.
 - a. If the taper-lock is installed on the impeller, remove it by inserting the (3) taper-lock bolts into the smaller, threaded holes in the bushing and tightening them down until taper-lock releases from the impeller hub.
 - b. Pry the taper-lock slightly open by inserting a flat-head screwdriver into the slit.
3. Attach the taper-lock bushing to the impeller:
 - a. Insert the (3) taper-lock bolts into the **larger, non-threaded** holes in the taper-lock bushing.
 - b. Slide the taper-lock into the hub in the center of the impeller, lining up the taper-lock bolts with the **threaded** holes on the impeller.
 - c. Finger-tighten the bolts to secure them in place.

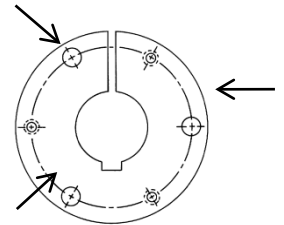

Make sure the taper-lock bolts are inserted through the larger, non-threaded holes in the taper-lock bushing, into the threaded holes of the impeller. The alternate set of holes is used for impeller removal only.

4. Position the impeller:
 - a. Slide the impeller onto the motor shaft, with the taper-lock bushing facing up.
 - b. Insert the motor key and lightly tighten the setscrew using a $\frac{3}{32}$ " hex key until it cannot fall out.
 - c. For single phase motors, lift the impeller so that the taper-lock is flush with the top of the motor shaft.
 - d. For three phase motors, lift the impeller so that the taper-lock sits $\frac{1}{4}$ " below the top of the motor shaft.

5. Tighten the taper-lock bolts:
 - a. Consecutively tighten each taper-lock bolt by a $\frac{1}{4}$ revolution, until they are all tight.



The tightening of each bolt will cause the subsequent bolts to feel as if they've loosened.

- b. Repeat this process until each bolt is torqued to the manufacturer's specification of 5 ft/lbs.



Upon completion, there should be a minimum of $\frac{1}{4}$ " clearance between the back of the impeller and the motor bolts installed in the motor plate. There may also be up to a $\frac{1}{16}$ " – $\frac{1}{8}$ " gap between the taper-lock bushing and the impeller hub.

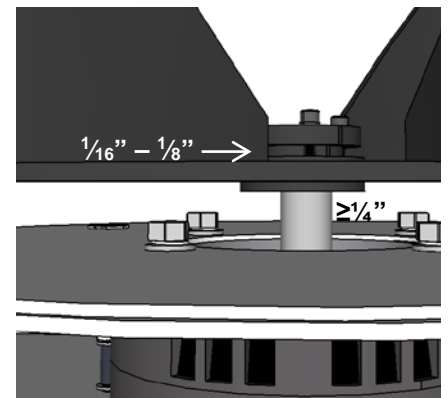

6. Firmly tighten the setscrew against the motor key using a $\frac{3}{32}$ " hex key.

Hanging the Motor/Impeller Assembly



If you purchased an Electrical Box with your system, it is recommended that you wire the 6' whip into the wiring box of the motor first, prior to hanging the motor/impeller assembly. Please refer to the Electrical Box instruction sheet for more detail.

1. Hang the motor/impeller assembly:
 - a. With the help of your installation partner, turn the motor/impeller assembly over so that the fins of the impeller are facing downward.
 - b. Rotate the assembly so that the wiring box on the motor will be accessible, once mounted.
 - b. Slide the assembly onto the Wall Mounting brackets – the hanger plate can be situated either lengthwise or widthwise, depending on installation.
2. The motor/impeller assembly will be secured to the Wall Mounting Brackets after the cyclone has been installed. This allows for the ability to move the motor/impeller assembly in or out a couple of inches to make installation of the cyclone easier.

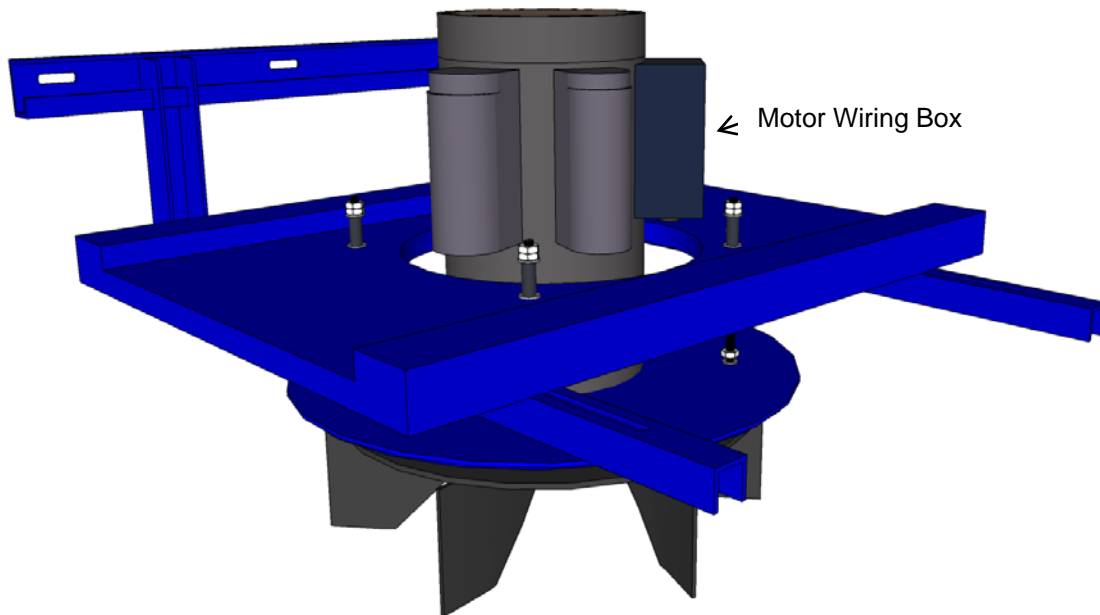

Do NOT turn the motor on until the system is completely assembled, including the collection drum. Doing so may cause the circuit breaker to trip, physical damage to the system and/or bodily harm.

Assembling the 90° Filter Transition *(filtered systems only)*

1. Begin by inserting the outer and inner plastic sides into the grooves of the side plates to form the transition.

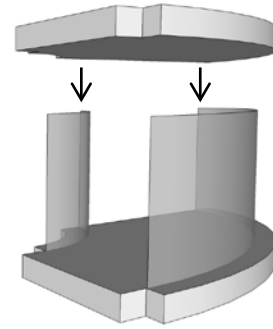
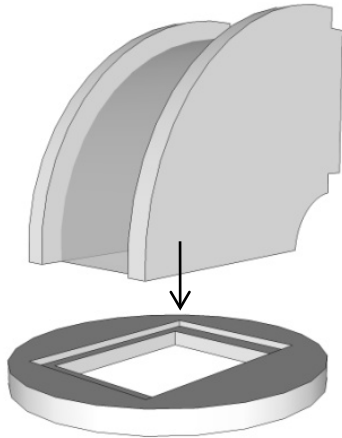

2. Slip the assembled sides of the transition into the slot of the round end plate
 - a. The straight ends of the two MDF side plates should be seated into the groove of end plate.

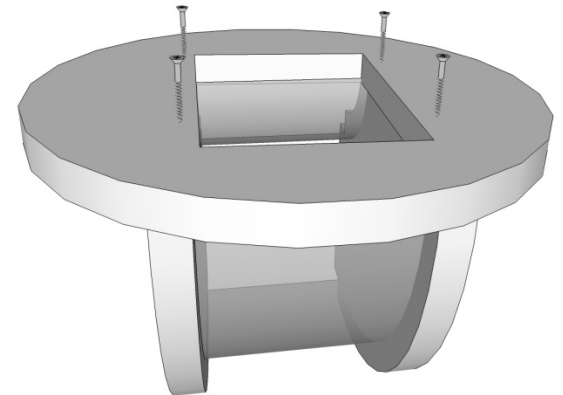

3. Secure the filter transition end plate:
 - a. Drill (4) small pilot holes in the bottom of the round end plate.
 - b. Attach the transition end plate using (4) #6 x 1-1/4" sheet rock screws.



Do not caulk the seams of the 90° Filter Transition until it is installed on the blower housing.



Attaching the 90° Filter Transition (*filtered systems only*)

1. Using a 7/16" wrench, loosen the (4) bolts closest to the rectangular opening on the blower housing and expand it slightly.
2. Slip the 90° filter transition onto the blower housing with the sides of the transition outside of the plastic wrapper of the blower.
 - a. Tighten the bolts on the blower housing to clamp the transition in place.

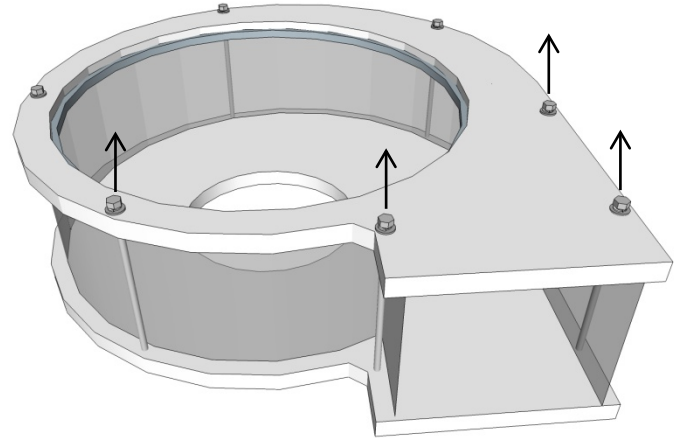

3. With the transition positioned, drill (2) holes through each side of the transition where it overlaps with the blower housing plastic wrapper, using a 5/16" bit.

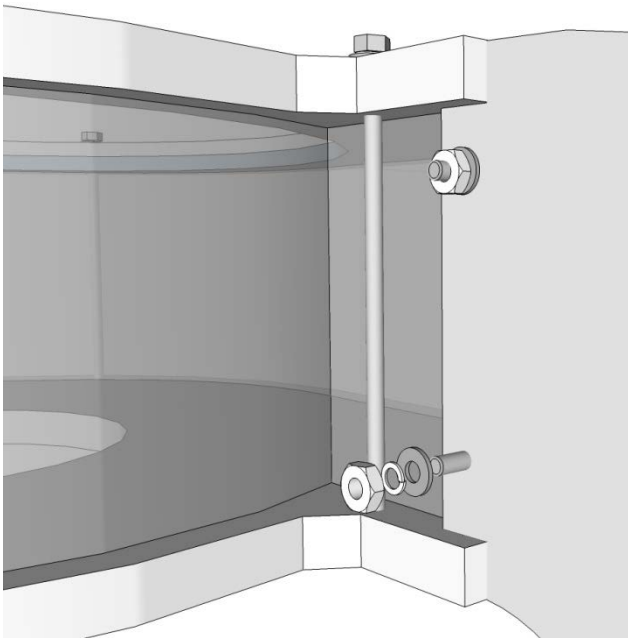

4. Insert a 1/4"-20 x 1-1/2" hex bolt into each hole from the inside, with the ends pointed towards the exterior of the assembly.
 - a. Secure the transition in place using a 1/4"-20 lock washer, 1/4"-20 flat washer and a 1/4"-20 nut.
 - b. Repeat for (3) remaining holes.
5. Center the two plastic sides of the transition between the blower housing and the transition end plate by sliding them up or down accordingly.

6. Caulk the seams of your blower housing (where plastic meets MDF), as well as where the 90° filter transition attaches to the blower housing, using clear silicone caulk. Be sure to cover all seams.



Sealing your blower housing and transition is very important. If there are any leaks, the unit will blow fine dust into your shop.



Do not remove the white block of wood mounted to the inside of your blower housing. This block counters the sound as the impeller blade passes by the larger opening of the blower housing, reducing noise.

Attaching the Straight 8" Exhaust (*non-filtered systems only*)

1. Using a 7/16" wrench, loosen the (4) bolts closest to the rectangular opening on the blower housing and expand it slightly.

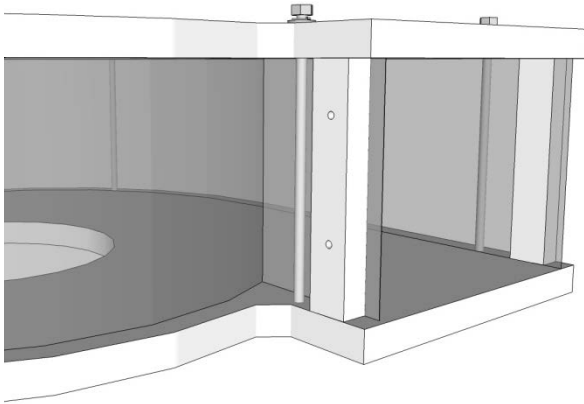
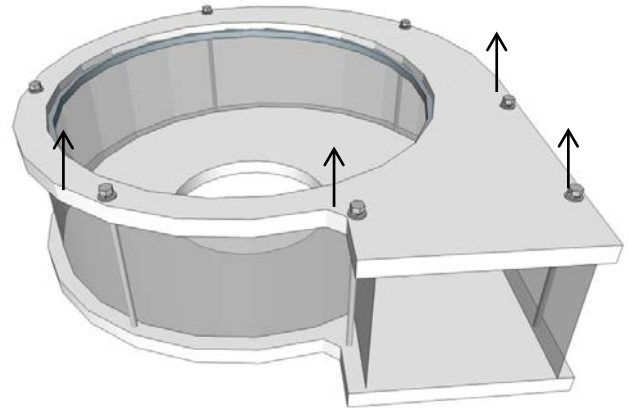

2. If not already installed, place the white mounting sticks on the outside of the blower housing's plastic wrapper.
 - a. The blocks will be marked left and right.
 - b. Line up the pre-drilled holes on the blocks with the holes on the plastic wrapper.
 - c. Tighten the bolts on the top of the blower housing to clamp the mounting sticks in place.

3. Place the straight 8" exhaust over the opening of the blower housing and line up the pre-drilled holes with the holes on the mounting sticks.

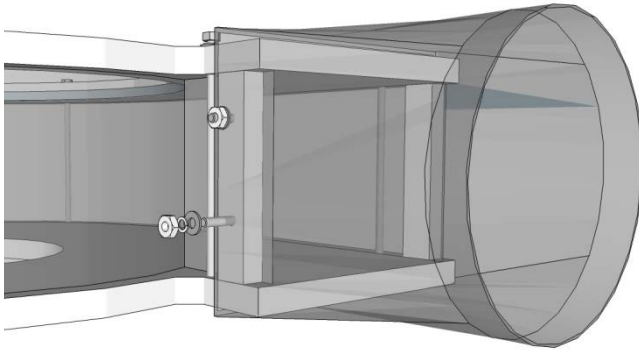

4. Insert a 1/4"-20 x 1-1/2" hex bolt into each hole from the inside, with the ends pointed towards the exterior of the assembly.
 - a. Secure the transition in place using a 1/4"-20 lock washer, 1/4"-20 flat washer and a 1/4"-20 nut.
 - b. Repeat for (3) remaining holes.
5. The exhaust is sized to receive 8" sewer and drain PVC, which is then used to duct to the final termination point outdoors.

7. Caulk the seams of your blower housing (where plastic meets MDF), as well as where the straight 8" exhaust attaches to the blower housing, using clear silicone caulk. Be sure to cover all seams.



Sealing the exhaust is very important. If there are any leaks, the unit will blow fine dust into your shop.



Do not remove the white block of wood mounted to the inside of your blower housing. This block counters the sound as the impeller blade passes by the larger opening of the blower housing, reducing noise.

Attaching the Blower Housing to the Cyclone Body

1. Place the cyclone body, right-side up and well-supported, in a drum or bin to keep the unit from tipping over. If a drum or bin is not available, the cyclone's shipping box can be shortened and used for support as well.
2. Set the blower housing on top of the cyclone. Determine the desired orientation of the cyclone intake relative to the exhaust opening on the blower housing.



The position of the intake can be rotated in any direction with respect to the exhaust. This will not affect system performance in any way.

3. Secure the blower housing to the top of the cyclone body with (6) #6 x 1-5/8" sheet rock screws, using the pre-marked divots on the blower housing bottom as guides.
4. With the assistance of a helper, lift the cyclone body up so that the impeller is seated within the blower housing and the motor plate is aligned with the opening on the top of the blower housing.
 - a. If no help is available, remove the cyclone from the drum or bin used to secure it in step 1 and place a piece of plywood across the top of the container. Carefully position the cyclone body on top of the plywood and under the motor assembly, ensuring it does not tip, maintaining contact at all times. Slip a series of boards under the cyclone to lift the unit until the motor plate is correctly aligned with the top of the blower housing.
5. Secure the blower housing to the motor plate:
 - a. Reinstall the (6) clips removed earlier using using (1) 1/4"-20 x 1-1/2" hex bolt, (1) 1/4"-20 lock washer, and (1) 1/4"-20 flat washer per clip.
 - b. Leave the clips loose enough to allow for rotation of the cyclone.

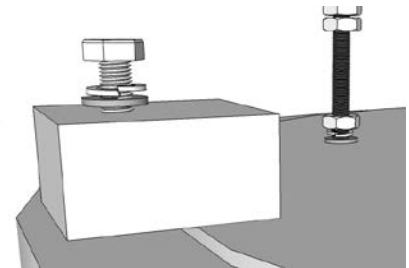
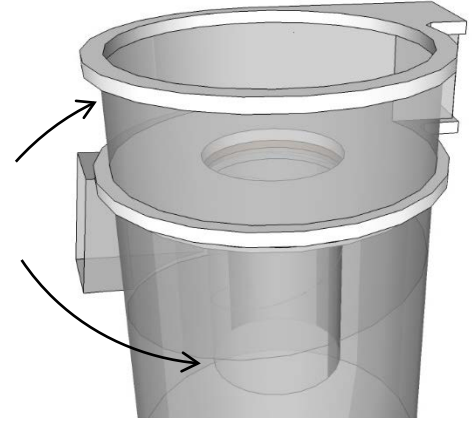

The motor plate will not sit flush with the top of the blower housing by design.



It is not necessary to seal the seam between the cyclone and blower housing, or the seam between the blower housing and motor plate, with silicone.

Installing the Intake and Leveling the Cyclone

1. Rotate the cyclone, if necessary, so the portion of the intake chute extending from the cyclone body is accessible.
2. Attach the intake transition to the cyclone by lining up the pre-drilled holes and inserting (4) #6-18 x $\frac{3}{8}$ " pan head screws.
3. Seal the seam between the chute and transition with silicone.
4. Rotate the cyclone, if necessary, into position and tighten the (6) clips on the top of the blower housing.

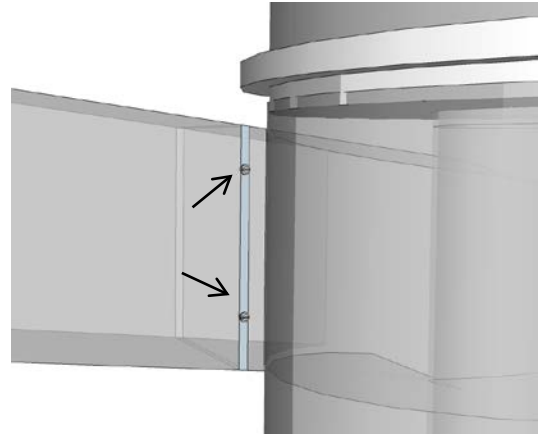

 *The position of the cyclone/blower housing assembly can be rotated in any direction. This will not affect system performance in any way.*

5. Place a level across the top of the blower housing to ensure that the cyclone is level.
 - a. To raise the system upward, tighten the $\frac{1}{4}$ "-20 nuts above the hanger plate, moving them down the threaded rod assembly towards the floor. Loosen the $\frac{1}{4}$ "-20 nuts below the hanger plate as needed.
 - b. To lower the system downward, loosen the $\frac{1}{4}$ "-20 nuts above the hanger plate, moving them up the threaded rod assembly towards the ceiling.

 *When finished, the cyclone should be within a $\frac{1}{4}$ " of being level in all directions.*

6. Tighten the $\frac{1}{4}$ "-20 nuts above and below the hanger plate so they are snug without causing the bushings to bulge.

Wonder why there's a hole in the side of your cyclone?

This hole allows for a small amount of air movement in the area above the inner ramp in order to prevent dust from accumulating over time.

Do not plug this hole!

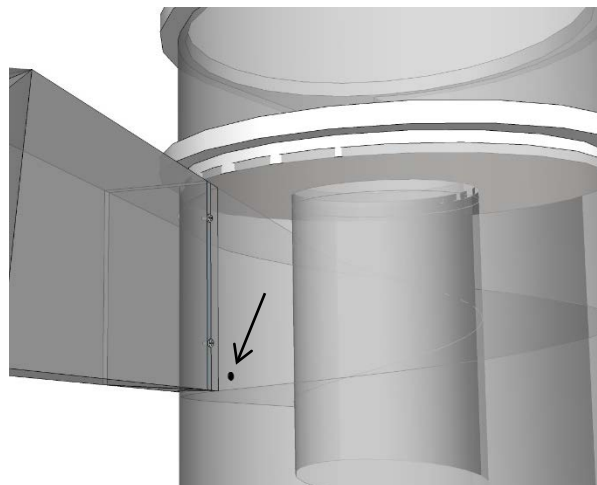

Building your own Filter Clean Out Box *(filtered systems only)*

Note: Filter Clean Out Boxes are available for purchase at www.clearvecyclones.com.



The only requirement for building your own filter clean out box is that it is airtight when closed and has an opening to remove the dust collected.

1. Determine the height of your filter clean out box:
 - a. Measure the distance from the bottom of the 90° filter transition to the floor.
 - b. Subtract the height of the filter stack (68") to determine the required height for the filter clean out box.
2. Build the box out of $\frac{3}{4}$ " plywood or MDF, nails and wood glue:
 - a. The recommended dimensions are 14" x 14" x the height determined in step 1.
 - b. The box should have a hole cut out of the top approximately 8- $\frac{1}{2}$ " in diameter.
 - c. Cut a rectangular access opening on the front of the box for clean out purposes.
 - d. Build the cover plate larger than the access opening, to cover the opening in its entirety. Use $\frac{1}{2}$ " thick by 1" wide gasket or weather stripping around the inside edge of the cover plate for an airtight seal.
 - e. Use wood screws to secure the cover plate in place during use.

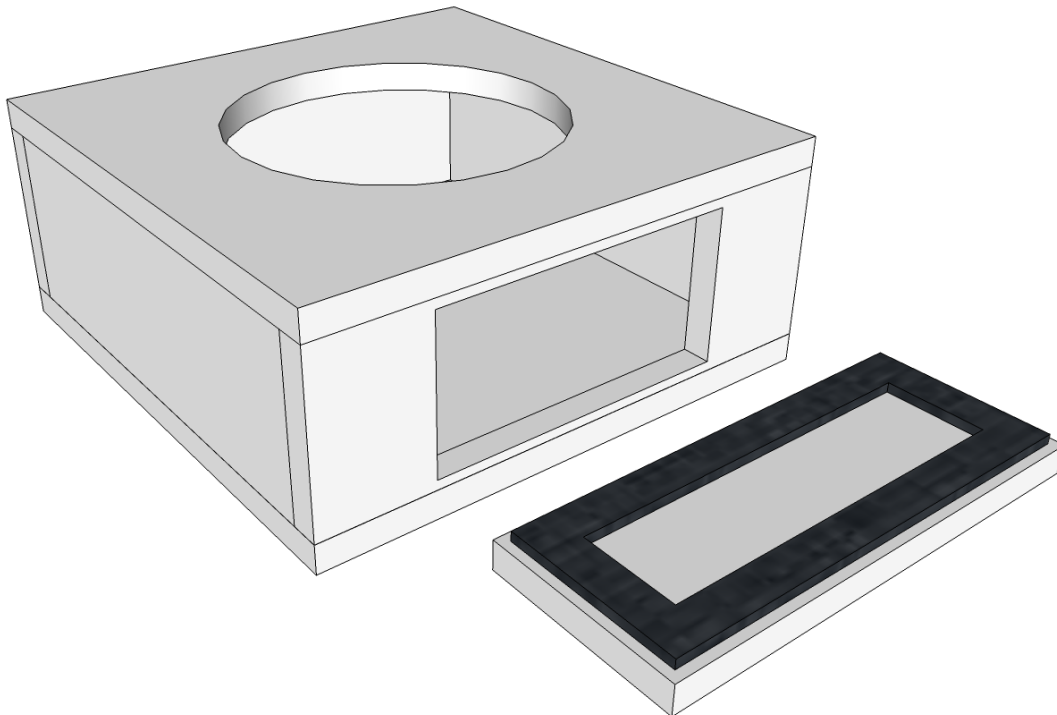

Assembling the Flangeless Filter Stack *(filtered systems only)*



If your filters are the flanged style, please contact Customer Service for assembly instructions.

1. Stack the two filters together, one on top of the other.
2. Run a bead of silicone caulk around the outside of the seam where the two filters meet.
3. Secure the band clamp:
 - a. Place a ¼"-20 flat washer on the ¼"-20 x 1" bolt.
 - b. Wrap the band clamp around the seam between the two filters.
 - c. Insert the ¼"-20 x 1" bolt with the ¼"-20 flat washer through the hole on the band clamp and tighten.
 - d. Place a ¼"-20 wing nut on the hex bolt and tighten.
4. Place the stacked filters on top of the filter clean out box.
5. Run a bead of clear silicone caulk around the base of the filters, where they meet the filter clean out box, to ensure an airtight seal.
 - a. The silicone caulk will hold the filters securely in place and can be removed easily by cutting the bead with a razor knife.
6. If you purchased a filter clean out box from us, it will be caulked once the filter stack is installed.

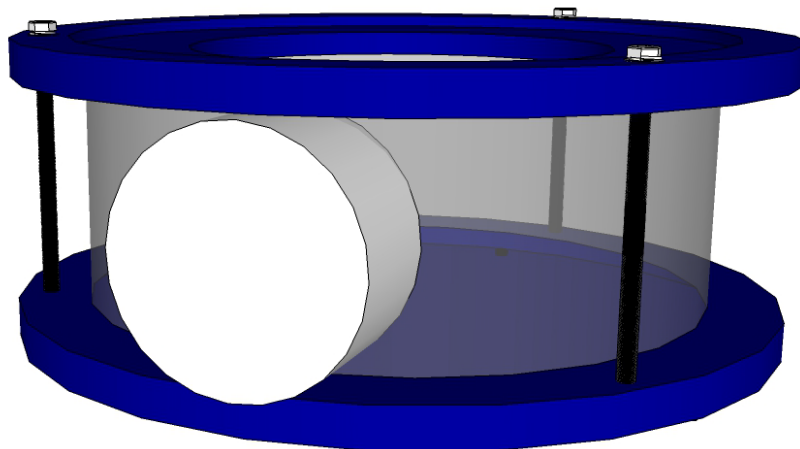
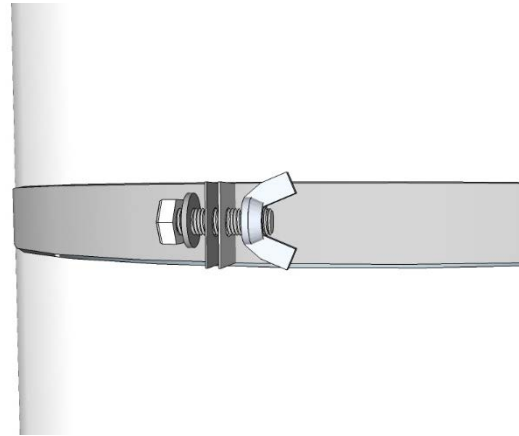

Filter Clean Out Box available for purchase at www.clearvuecyclones.com

Installing the Filter Stack Assembly *(filtered systems only)*

1. Slide the filter stack assembly under the 90° filter transition. The fit should be exact.

 *If you purchased our Filter Clean Out Box with your system, its height can be adjusted from 5- $\frac{3}{4}$ " – 7- $\frac{1}{2}$ " by extending the three $\frac{1}{4}$ "-20 bolts on the bottom.*



If you are installing your system higher than 96", the filter stack assembly will need to be supported from below.

2. Secure the filter stack assembly to the 90° filter transition end plate:
 - a. Drill (3) pilot holes in the MDF and attach the filter stack assembly using (3) 1- $\frac{1}{4}$ " #6 sheetrock screws.



These screws are not meant to be load-bearing in any way. They are intended to keep the connection secure if the filter stack is accidentally bumped.

- b. Run a bead of clear silicone caulk around the seam where the 90° filter transition end plate meets the top filter.
3. If you purchased a Filter Clean Out Box from us, caulk the seams where the PETG wrapper meets the MDF top and bottom.

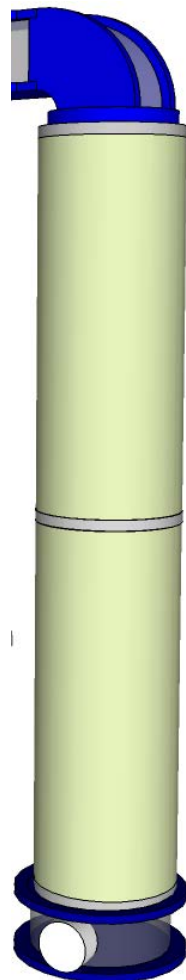

Completed Filter Stack Assembly

Modifying the Collection Drum Lid



The collection drum is not included with system purchase. Any size drum can be used as long as it is round, airtight, not subject to collapse and as long as you have the ceiling height to support it. Our standard 96" install allows for a drum no taller than 27" in height. Usually this equates to a 30-gallon metal trash can available for purchase at your local hardware store. If you use a taller drum, you will need to raise the mounting height of the system.

Please contact Clear Vue Customer Service if you need assistance sourcing your drum.

Option 1: Metal Trash Can Lid

1. Cut a hole in the center of the metal lid:
 - a. Draw a 3" radius (6" diameter) circle, centered on the top of the lid using a fine point marker.
 - b. Draw a 2-³/₄" radius (5-¹/₂" diameter) circle centered inside of the larger circle.
 - c. Cut out the smaller circle using snips, jig saw or other appropriate tool.
2. Using pliers and snips, use the outer circle as a guide to bend a ¼" lip in order to create a collar to attach the flex hose.
3. Use ½" thick by 1" wide gasket or weather stripping around the underside of the lid where it contacts the trash can for an airtight seal.
 - a. For further reinforcement, bungee cords may be stretched across the lid, on either side of the flex hose, and attached to the ends of the handles.

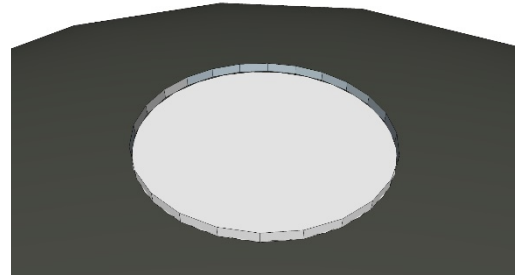

Option 2: Alternate Lid Types

If your drum does not support option 1, you can source a 6" HVAC starting collar (also called a take-off collar) from your local hardware store.

1. Cut a 6" hole in the center of the lid.
2. Mount the starting collar from the underside of the lid, up through the hole.
3. Seal the seams between the lid and collar, both on top and underneath, with clear silicone caulk.



HVAC starting collars can potentially add to the height of your collection drum. It is recommended to have at least 1" of distance between the base of the cyclone and top of the collar to allow for room to remove the lid. You may need to shorten the height of your collar accordingly.

Installing the Collection Drum and Final Adjustments

1. Attach the short length of 6" flex hose provided to the collar on the collection drum lid.
 - a. Secure the hose to the collar with a 6" flex hose clamp.
 - b. Caulk the hose from both sides of the lid to seal it in place.
2. Attach the lid to the cyclone:
 - a. Place a 6" flex hose clamp over the top of the flex hose. Make sure it is loose.
 - b. Install the lid by placing the 6" flex hose over the base of the cyclone.



The flex hose will be an extremely tight fit around the base of the cyclone. This is by design in order to make sure the connection is air tight. The flex hose can be made more pliable for installation by heating it with a hair dryer.



Make sure the notch at the base of the cyclone is fully covered by the flex hose.

- c. Tighten 6" flex hose clamp to secure flex hose to the base of the cyclone.
- d. Run a bead of clear silicone caulk around the seam at the top of the flex hose.



A longer length of flex hose may be used between the base of the cyclone and collection drum lid, if needed.

3. Secure the hanger plate to the wall mounting brackets:
 - a. Pre-drill holes in the hanger plate.
 - b. Screw the hanger plate to the horizontal member of the wall mounting brackets using either 1- $\frac{1}{4}$ " sheet rock screws or $\frac{1}{4}$ "-20 x 1- $\frac{1}{4}$ " bolts (not included).

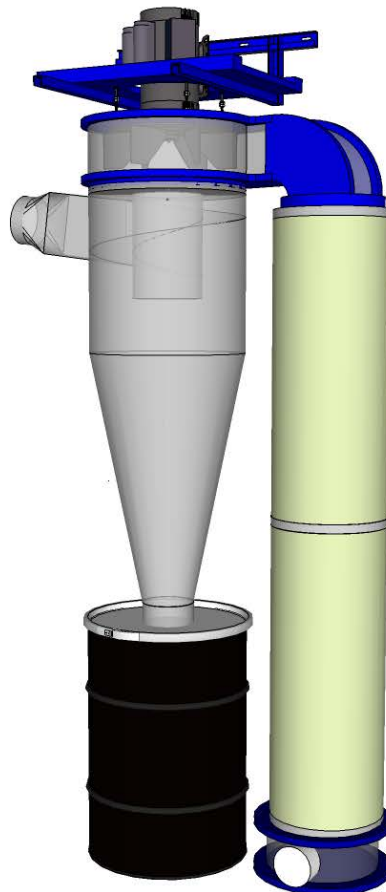

Electrical – Single-Phase Motors



Clear Vue Cyclones highly recommends the use of a professional, licensed electrician to complete the wiring and any electrical work associated with this installation. Significant damage to your system and/or bodily harm can result.



The Leeson 5HP motor is designed to rotate either clockwise or counter-clockwise. Motors are prewired direct from Leeson and may be wired for either rotation. You will need to check the wiring to ensure it is correct.



If you purchased our prewired Electrical Box, which gives you a remote start for your system, please refer to the assembly sheet included with this item.

1. Follow the directions on the Leeson motor for wiring the motor for a clockwise rotation:
 - a. Connect **L1** to **P1**.
 - b. Connect **L2** to both **T4** & **T8**.
 - c. Connect **P3** & **T1** & **T5** – wire together and cap off with a wire lug.
 - d. Connect the ground wire (bare wire) to the green screw inside the motor connection box.



Leeson recommends the use of wire lugs in lieu of wire nuts to secure all connections.



Leeson defines motor rotation with the motor shaft facing away. For our installation purposes, rotation is defined from the opposite end of the motor. In order to obtain a counter-clockwise rotation when viewed from below, please follow the clockwise instructions on Leeson's motor plate, which match step 1 above.

Once the motor is wired, the motor shaft and impeller blade should be turning **counter-clockwise when viewed from below** (i.e.: looking up at the impeller from the floor).

Note that our impellers are backward inclined, allowing our system to move high volumes of air at a variety of static pressures. Each blade on the impeller has a slight "C" shape. When rotating correctly, the convex side of the blade will be hitting the air first. This rotation will match the yellow rotation sticker on your blower housing.

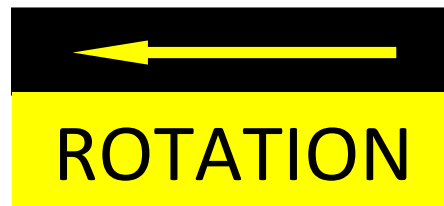
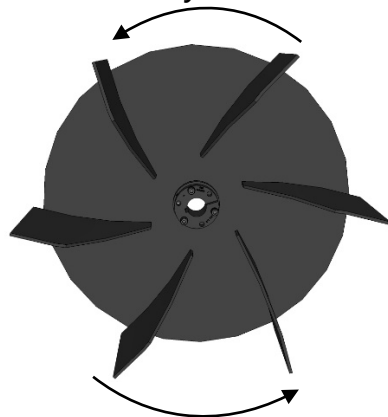

2. If you did not purchase the prewired Electrical Box and wish to use a 110v switch to power your system, we have included a relay with your shipment for this purpose. Please use the following wiring diagram:

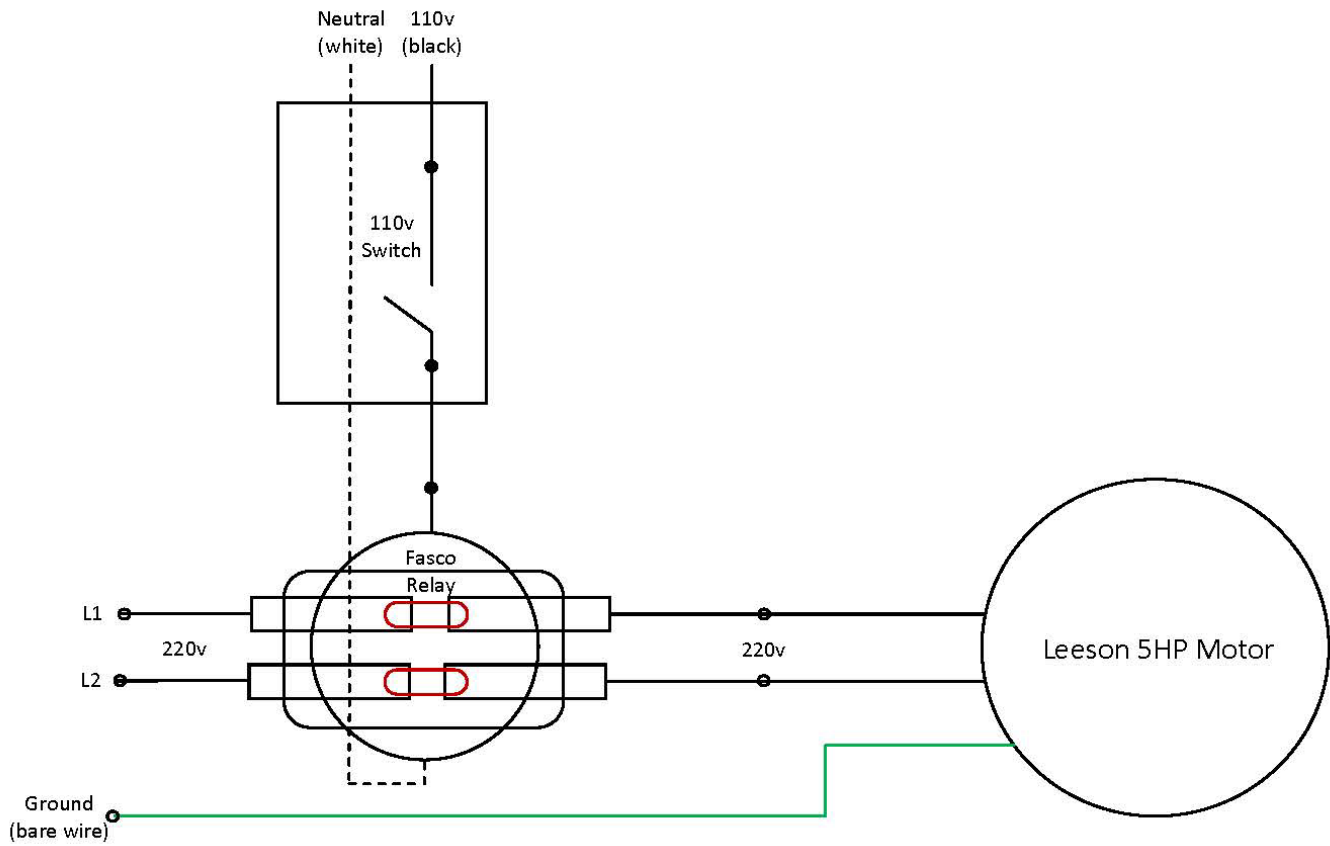

Electrical – Three-Phase Motors

VIEW FROM OUTSIDE OF MOTOR AT SWITCH END.

005010-20

LINE LEADS

VOLTAGE	L1	L2	L3	JOIN & INSULATE
HIGH	T1	T2	T3	(T4, T7) (T5, T8) (T6, T9)
LOW	T1, T7	T2, T8	T3, T9	T4, T5, T6

TOLERANCES UNLESS OTHERWISE SPECIFIED		DECIMALS	
	± .01		
	± .005		
	± .0005		
	± .000		
	± 1/64		
	± 1/2°		

	DRAWN DBT 12/16/97	TITLE	EXTERNAL WIRING DIAGRAM
	CHK'D.		3 PHASE W/O PROTECTOR
01	UPDATED REV TO MATCH ORACLE	APPR. JJK 04/20/00	MATL. BRF
NO.	REVISION	BY DATE	DECAL - 004014
			(TSTAT) - 080582
			FINISH STOCK
			SIZE A
			DRAWING NO. 005010-20

LEESON ELECTRIC CORPORATION			
------------------------------------	--	--	--



Leeson recommends the use of wire lugs in lieu of wire nuts to secure all connections.